



Neighbourhood Development Programme

URBAN HUB DESIGN TOOLKIT

THE MUNICIPAL GUIDE: Getting your hub started



national treasury

Department:
National Treasury
REPUBLIC OF SOUTH AFRICA





Neighbourhood Development Programme

URBAN HUB DESIGN TOOLKIT

THE MUNICIPAL GUIDE: *Getting your hub started*

ACKNOWLEDGEMENTS

The Neighbourhood Development Programme is funded by the South African Department of National Treasury. Photographs and images reproduced in this Toolkit are with the permission of the Johannesburg Development Agency (JDA) and NM & Associates Planners and Designers. Research and development of the Toolkit was undertaken by: **NM & Associates Planners and Designers**, P.O Box 44386, Claremont, Cape Town, 7735 South Africa
T. +2721-422-0822 | **E:** jody@visionplan.co.za

Produced by the South African Government's Neighbourhood Development Programme (NDP) as an abridged version of the Practitioner's Manual which can be accessed via the NDP's website: ndp.treasury.gov.za

Co-ordinated by: David van Niekerk

Neighbourhood Development Programme

240 Madiiba Street, Pretoria, 0001 South Africa

T. +2712-315-5075 | **E:** David.VanNiekerk@treasury.gov.za



national treasury

Department:
National Treasury
REPUBLIC OF SOUTH AFRICA



**CREATING URBAN NETWORKS.
RESHAPING SOUTH AFRICA'S CITIES.**



URBAN HUB DESIGN TOOLKIT

THE MUNICIPAL GUIDE: *Getting your hub started*

CONTENTS

| | |
|--|---|
| Introduction: | 1. THE TOOLKIT IN CONTEXT 2 2. URBAN HUB CONCEPT 4 3. PROCESS GUIDE 6 4. TASK GUIDELINES 8 |
| a Analyse Key Informants: | 5. IDENTIFY KEY INFORMANTS 10 6. ANALYSIS OF OPPORTUNITIES, CONSTRAINTS AND CHALLENGES 12 |
| b Produce Access and Movement Framework: | 7. CONSIDER HUB TO CITY CONNECTIVITY 14 8. APPLY THE INTERCHANGE ZONE CONCEPT 16 9. MAKE THE ACCESS GRID VISIBLE 18 10. LOCATE THE PEDESTRIAN WAYS 19 11. CONSIDER TRANSPORT INFRASTRUCTURE 20 12. PRODUCE AN ACCESS AND MOVEMENT FRAMEWORK 21 |
| C Prepare Land Use Framework: | 13. IDENTIFY CONCEPTUAL ZONES 22 14. CONSIDER HOUSING TYPOLOGIES 24 15. IDENTIFY AND LOCATE THE MAIN LAND USES 26 |
| d Conceptualise The Form of Development | 16. CONCEPTUALISE THE FORM OF DEVELOPMENT 28 |
| e Develop Place-Making Guidelines | 17. DEVELOP PLACE-MAKING GUIDELINES 30 |
| f Develop A Phasing Plan | 18. DEVELOP A PHASING PLAN 32 |
| Evaluation: | 19. EVALUATION GUIDE 36 |
| Annexures: | 20. DEFINITIONS AND ACRONYMS 40 |



URBAN HUB DESIGN TOOLKIT

THE MUNICIPAL GUIDE: *Getting your hub started*

FIGURES

| | | |
|------------|--|-----------|
| Figure 1: | Urban Network Support Guide | 3 |
| Figure 2: | Urban Network Concept | 4 |
| Figure 3: | Interchange Zone Concept | 5 |
| Figure 4: | Illustrates common problems of public spaces | 9 |
| Figure 5: | Illustrates a busy, healthy gathering place that encourages activity | 9 |
| Figure 6: | Example - Urban Hub Study Area | 11 |
| Figure 7: | Map Indicating Opportunities, Constrains and Challenges | 12 |
| Figure 8: | Aerial Photograph of Bridge City which Demonstrates Typology | 15 |
| Figure 9: | Public Space Linking Public Transport Facilities and Commercial Areas (Stratford Interchange, UK) | 16 |
| Figure 10: | Street Vending Enlivening Links Between Public Transport Facilities (Warwick Triangle) | 16 |
| Figure 11: | Aerial Photograph of Mitchell's Plain Town Centre, Showing Application of the Interchange Zone Concept | 17 |
| Figure 12: | Development of the Access Grid | 18 |
| Figure 13: | A Vibrant Pedestrian Route in Mitchells Plain Town Centre | 19 |
| Figure 14: | A Modern Public Transport Interchange which Hosts Rail, Bus and Taxi Services | 20 |
| Figure 15: | Stages in Development of an Access and Movement Network | 21 |
| Figure 16: | Conceptual Zones | 23 |
| Figure 17: | Mixed Use Building with Residential Accommodation Above Shops | 25 |
| Figure 18: | Land Use Layers that Make Up the Conceptual Land Use Framework | 27 |
| Figure 19: | Illustrations of Key Urban Design Principles | 29 |

URBAN HUB DESIGN TOOLKIT

THE MUNICIPAL GUIDE: *Getting your hub started*

INTRODUCTION

1. The Toolkit in Context
2. Urban Hub Concept
3. Process Guide
4. Task Guidelines

1. THE TOOLKIT IN CONTEXT

The eradication of spatial inequality is a national priority in terms of South Africa's National Development Plan. The Neighbourhood Development Programme, through its Urban Networks Strategy, supports this by providing technical assistance and grant funding to municipalities for capital projects that will leverage further public and private sector investment in strategic locations around the country.

URBAN NETWORK SUPPORT GUIDE

The Neighbourhood Development Programme Unit has developed an **Urban Networks Support Guide and Road Map** (Refer to the diagram on next page) with a proposed planning process as well as a number of best practice toolkits and manuals to support spatial targeting at the city and precinct levels and infrastructure project pipelining and spatial planning. The Urban Hub Toolkit is one of the supporting toolkits and describes a methodology to support planning and design of Urban Hubs. The design should be supported by a Precinct Plan for the Urban Hub to identify and prioritise projects and to prepare an implementation strategy for projects within the Urban Hub.

URBAN HUB DESIGN TOOLKIT

This Urban Hub Design Toolkit is a process guide and evaluation tool for municipal officials who will be overseeing the work of planners and designers engaged with Urban Network planning. This Toolkit works in conjunction with the Practitioners' Guide (this is available on the NDP Website <http://ndp.treasury.gov.za/>).

METHODOLOGY FOR THE IDENTIFICATION OF URBAN HUBS

This document does not include guidelines for identifying where Urban Hubs should be located, nor does it address implementation-related activities beyond the spatial aspects of phasing and its implications for institutional arrangements.

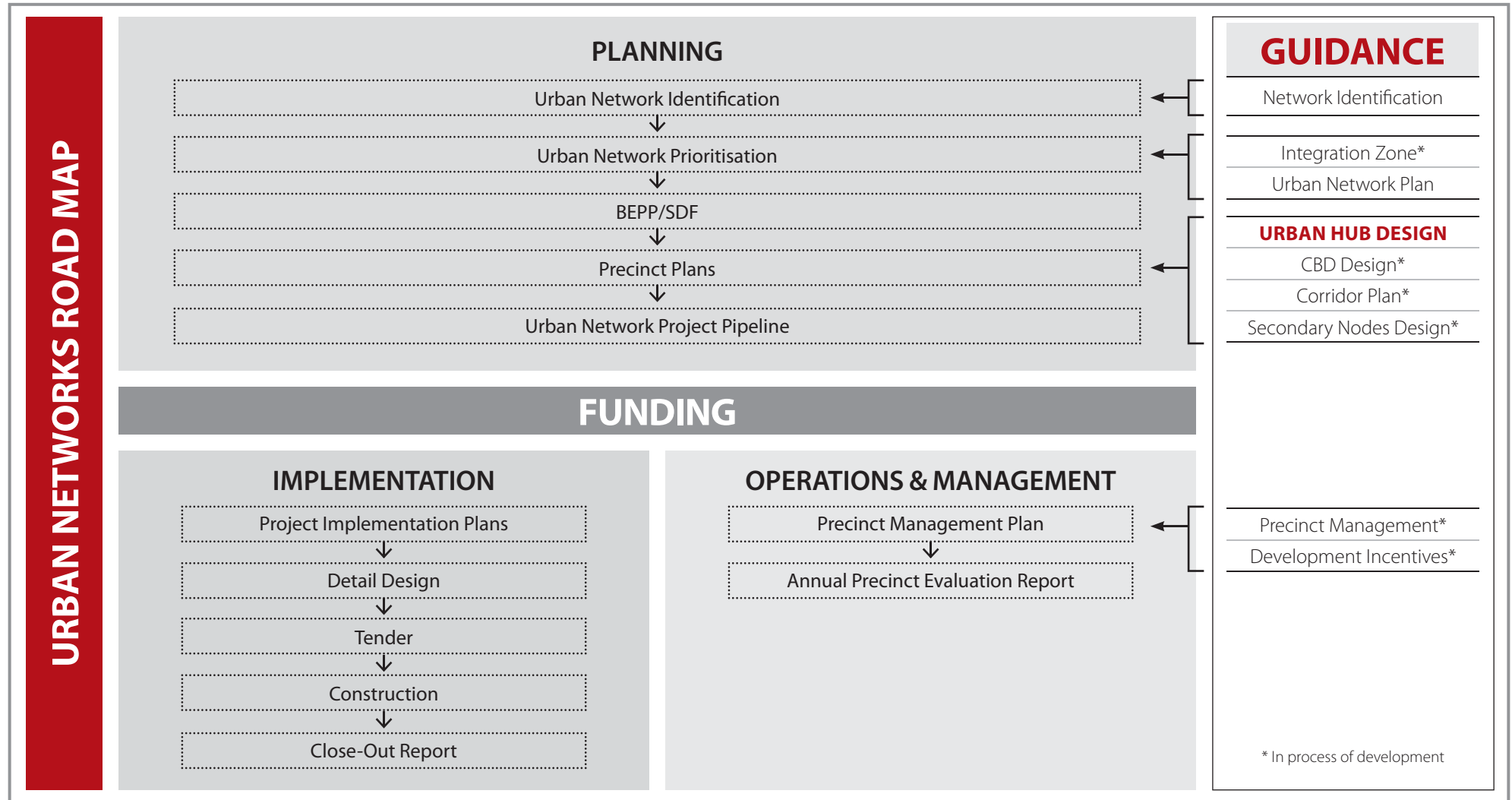


national treasury

Department:
National Treasury
REPUBLIC OF SOUTH AFRICA



Figure 1: Urban Network Support Guide



2. URBAN HUB CONCEPT

The diagram on the right summarises the approach of the NDP URBAN NETWORK STRATEGY for improving the spatial structure of South African cities. In the middle is a primary movement network with the CBD at its centre. Nodal points within the primary network connect via a network of high order public transport linkages (rail or BRT, preferably rail) to Urban Hubs in outlying townships or groups of townships. These are proposed as Primary Nodes which in turn are supported by Secondary Nodes.

The outlying **Urban Hubs**, as points of maximum connectivity clustered around a transport hub, should function as town centres. The Urban Hubs should offer important public services and commercial activities (employment, entrepreneurial opportunities) for local residents and should attract in people from a broader region or district. They should also include residential accommodation.

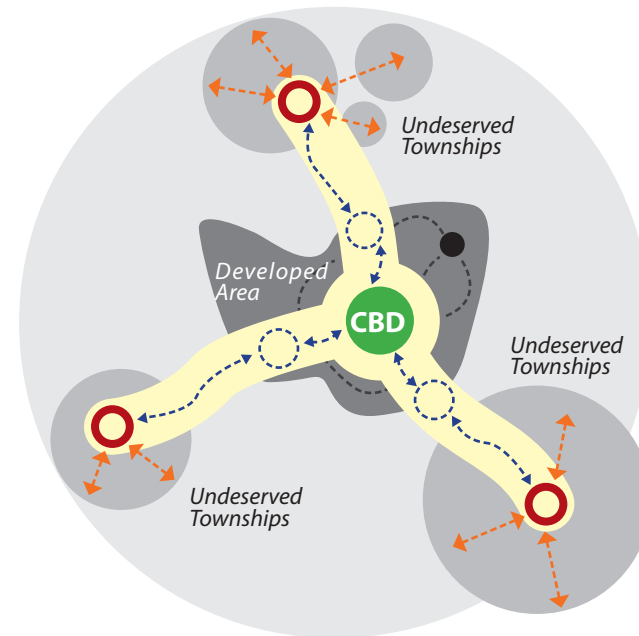
In order to succeed, Urban Hubs need 24/7 occupancy levels that can only be achieved through this mixing of land uses. Town centres the world over are being replanned according to this model to create more vibrant and sustainable urban environments.



Key objectives for the Urban Hubs are to:

- Create a sense of place by responding to local conditions of topography, climate, human needs, function and culture;
- Cater for those on foot (not at the exclusion of the car but always prioritised above the car); and
- Create a safe, convenient, secure and comfortable public space network, supported by a mix of land uses and activities that services the needs of residents, people working in the Hub and visitors to the Hub.

Figure 2: Urban Network Concept



| NETWORK ELEMENTS | PRIMARY NETWORK | SECONDARY NETWORK | INTERVENTION |
|---------------------------------|-----------------|-------------------|--------------------------------------|
| CBD | X | | Regeneration and management |
| Primary Transport Link | X | | Develop/Upgrade and management |
| Activity Corridor | X | | Infill & Densification |
| Urban Hubs | X | X | Mixed-use development and management |
| Secondary Transport Link | | X | Develop/Upgrade |

The Toolkit provides three key concepts / strategies to guide the restructuring of South Africa's outlying Urban Hubs towards this model of vibrant sustainability:

• THE INTERCHANGE ZONE

In an "Interchange Zone" rail, bus and taxi services come together within easy walking distance of one other. The connecting routes, or areas of movement, are designed to become areas of opportunity for retail and service-related businesses which will choose to locate along these movement routes due to the high pedestrian count, thereby offering increased levels of convenience for public transport users and ensuring that the Interchange Zone becomes a vibrant hub of activity that attracts people from near and far.

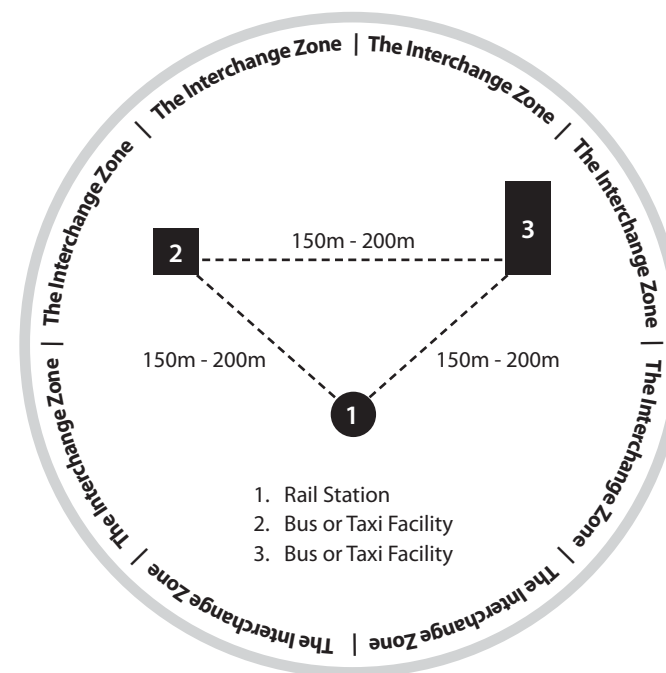
• MIXED USE DEVELOPMENT AND HOUSING 'COMPACTION'

Planning, design and management interventions in the Urban Hubs should aim to achieve horizontally and vertically integrated mixed use development. Particular attention should be given to how to integrate public service, social facilities, commercial and transport facilities in more compact models that challenge the present suburban patterns of low rise standalone pockets of development. New housing typologies that assist in achieving the required thresholds to support efficient public transport systems and can be integrated with these other land use will then contribute to the making of more efficient but lively public realm.

• VIBRANT, PEOPLE-FRIENDLY PUBLIC PLACES

The Hubs should aim to become socially, cultural and economically meaningful places for a range of people. In order to do so, the Hubs must provide a range of public spaces and places that are carefully crafted and above all else designed for the pedestrian.

Figure 3: Interchange Zone Concept



3. PROCESS GUIDE

The process of planning and designing an Urban Hub follows a progression from larger-scale concerns to a finer-scaled level of design, all of which are equally important to the quality of the end product. The Toolkit provides guidelines for step-by-step tasks in a sequence that reflects this progression. Tasks B and C address the structural aspects of the Urban Hub and land use patterns, producing two guiding plans: an Access and Movement Framework, and a Conceptual Land Use Framework.

This is followed by Tasks D and E which produce the Precinct and Sub-Precinct Plans, which give form to the urban objectives and design principles. Finally, Task F is the consideration of phased implementation of the plan. The diagram below demonstrates the linkages between the tasks and key deliverables of the planning and design methodology.

A

ANALYSE KEY INFORMANTS

STEPS

- Identify the main opportunities and constraints
- Identify local environmental, social and economic needs
- Confirm character and extent of hub
- Identify land use planning, policy and ownership limitations

DELIVERABLE
Status Quo Report

B

IDENTIFY STRUCTURING ELEMENTS

STEPS

- Identify main public transportation interventions
- Identify interchange zone
- Clarify movement routes
- Confirm pedestrian connections
- Identify transport infrastructure

DELIVERABLE
Access & Movement Framework

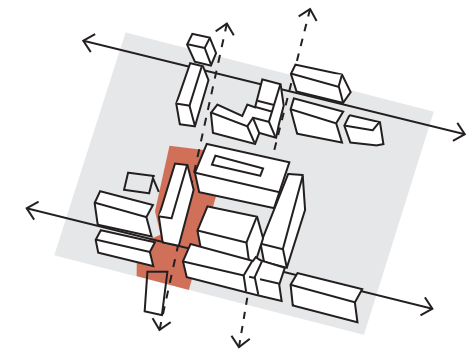
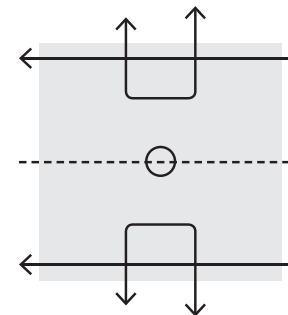
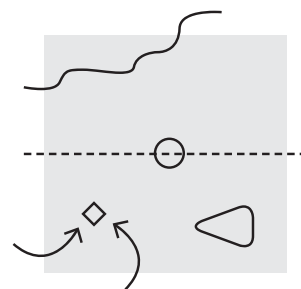
C

IDENTIFY AND LOCATE LAND USE COMPONENTS

STEPS

- Identify conceptual land use zones
- Consider housing typologies and densities
- Identify / locate land uses.

DELIVERABLE
Land Use Framework



D

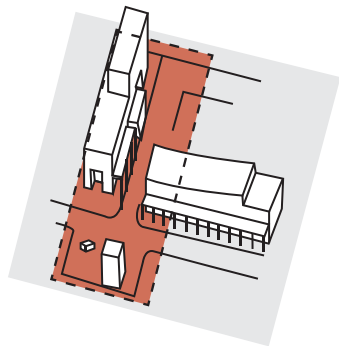
DESIGN SUB-PRECINCTS

STEPS

- Confirm sub-precincts
- Conceptualise form of development blocks in sub-precincts
- Locate and scale key public spaces and routes

DELIVERABLE

Sub-Precinct Plans
(Urban Design Framework)



E

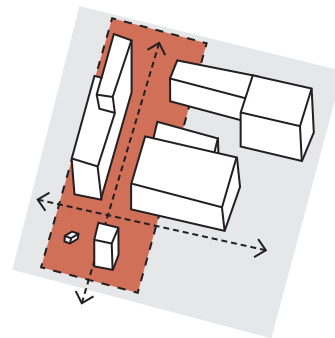
DEVELOP DESIGN GUIDELINES

STEPS

- Develop design guidelines and specifications
- Prepare urban design layouts for sub-precincts

DELIVERABLE

Design Guidelines,
Specifications and Urban
Design Layouts



F

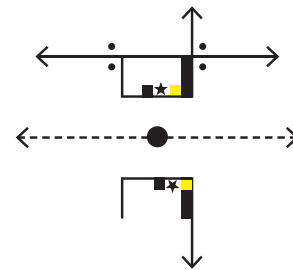
PREPARE PHASING PLAN

STEPS

- Prepare spatial phasing strategy

DELIVERABLE

Phasing Plan



G

EVALUATE

STEPS

- Using the checklist, assess deliverables / proposals

4. TASK GUIDELINES

The next sections of the Toolkit present a set of information sheets, each of which relate to a particular, objective-driven task so that, on completion, one has achieved something tangible.

They are presented here in a logical sequence but, because design is an iterative process, it is likely that tasks will be revisited and the design cycle repeated perhaps more than once before a final solution is agreed upon. Further, some tasks are more complex and detailed than others, and the particularities of a location will affect the degree of effort and time involved.

The images presented in this document are drawn from a selection of case studies in order to indicate particular good or bad features or they are graphic representations of an 'ideal' model.

Because many of the Urban Hubs will be already developed to a greater or lesser degree, planners and designers will need to exercise their skills in applying the Urban Hub concepts and principles of the 'ideal' model in order to achieve the best possible solution within a particular environment.





-  Each task is supported by an objective to be achieved.
-  Some tasks identify steps and key concepts to achieve the objectives.
-  The tasks are supported by tools that can be used to support or complete the task.
-  An Evaluation Guide is provided in the last section of the Toolkit to assist municipal co-ordinators of Urban Hub planning and design processes in assessing whether the deliverables are in line with the NDP's goal of developing vibrant and sustainable town centres.



Figure 4: Illustrates common problems of public spaces such as a lack of places to sit or of gathering points, the result are places that are neat, clean but empty.



Figure 5: Illustrates a busy, healthy gathering place that encourages activity.

URBAN HUB DESIGN TOOLKIT

THE MUNICIPAL GUIDE: *Getting your hub started*

A. ANALYSE KEY INFORMANTS

5. Identify Key Informants
6. Analyse Spatial Opportunities, Constraints and Challenges

5. IDENTIFY KEY INFORMANTS

The first task builds on information compiled during the prior process of identifying the Urban Hub, in the form of a series of status quo assessments and evaluation of the location's suitability according to a set of criteria that reflect NDP's requirements.



OBJECTIVE

The objective of the analysis is to prepare a baseline for decision making on the Urban Hub design.

Urban Hub planners will have inherited provisional boundaries for the study area which now need to be reviewed and possibly adjusted. The boundary should never be seen as 'fixed', because this would be counter-productive to the objectives of integration and movement, but it's necessary to set limits on the area to be planned. The area for analysis should be provisionally identified upfront before this exercise is initiated however the analysis itself may lead to the revision of the Urban Hub boundary.

Planners must identify key features, land marks as well as vacant and underutilised land, and developed areas that do not yet meet with the NDP's vision for the Urban Hubs, within an accessibility zone described by an 800 metre radius. The resulting 1600 metre diameter zone should include the rail and/or Bus Rapid Transit (BRT) station. It does not have to be located symmetrically over the rail station but should be adjusted so that it includes significant existing structures, amenities and other public transport hubs or routes.

Information should be mapped as far as possible to understand the spatial implications. Where an analysis shows no spatial implications they should be recorded to inform non spatial aspects of the implementation programme. Key components of the analysis could include the planning and regulatory environment, land use patterns, access and transportation, the social and economic context, infrastructure, the topographical, bio-physical, cultural/historical and spatial environment as well as climate and institutional aspects.



national treasury

Department:
National Treasury
REPUBLIC OF SOUTH AFRICA





STEPS

- Identify preliminary study area boundaries to ensure that the area to be analysed is scoped. There may be a primary study area and a secondary study area.
- Use (as far as possible) existing information to confirm the status quo for the area under investigation.
- Review only information relevant for the design and planning of the Urban Hub but use site visits to undertake spatial analysis.

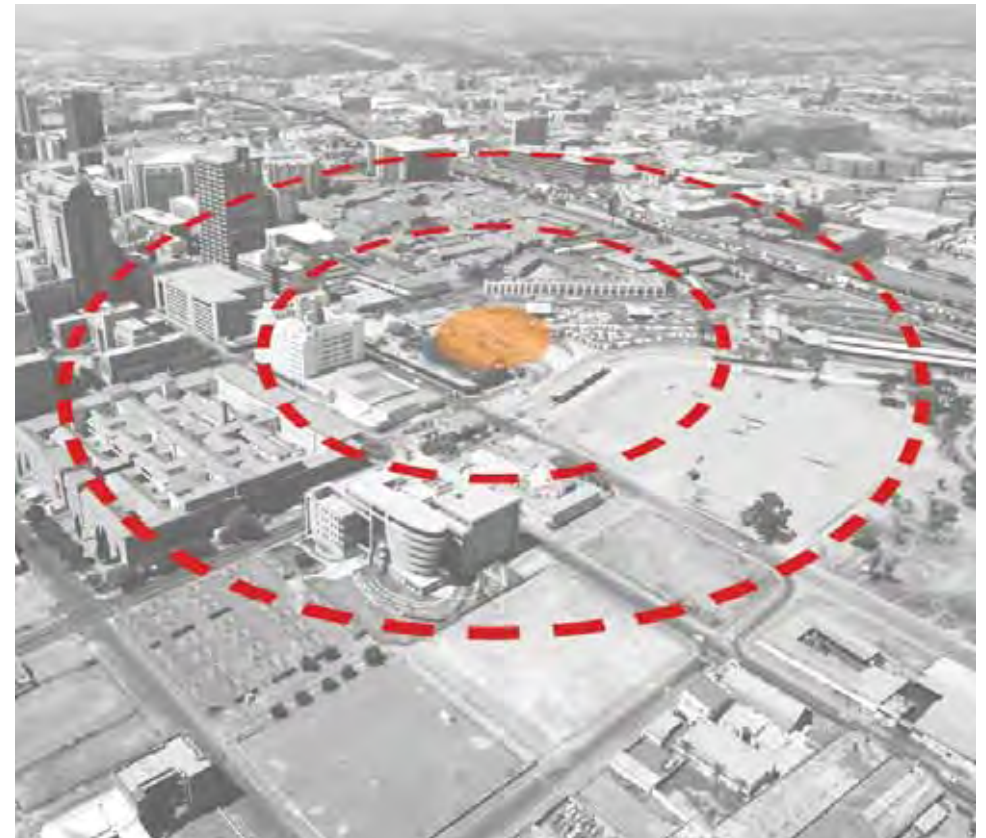


TOOLS

Existing municipal information including:


- IDPs,
- Transport Studies,
- Environmental Reports,
- Economic Assessments;
- Socio-Economic Surveys etc.

Figure 4: Example - Urban Hub Study Area



6. ANALYSIS OF OPPORTUNITIES, CONSTRAINTS AND CHALLENGES

Once baseline information has been gathered an analysis of key opportunities, constraints, challenges should be compiled.

**OBJECTIVE**

The objective of the analysis is to understand the key spatial opportunities, constraints and challenges.


The following should be identified, inter alia:

- Patterns of movement of goods and people, and problem areas. These could include inadequate infrastructure, crime hot spots and/or, particularly important, challenges to people moving on foot.
- Limitations to the extent of land available for new development, including ecologically sensitive areas, historically and culturally significant places or areas, servitudes, building setbacks, land that is already optimally developed.
- Spatial opportunities such as points of high convergence, key destinations, places, spaces and sites of cultural/historical/social significance, open land suitable for development, areas of ecological value and/or natural wonder that could provide public services.

The analysis must be included in the Status Quo Assessment Report, in the form of an Opportunities, Constraints and Challenges Map accompanied by a summary of findings.

The essence of the Urban Hub will be determined by those places, spaces, structures, natural features, activities that are unique to the site. They have the potential to define the future character of the node, and can provide its competitive edge. The nature of the Hub's special characteristics needs to be summed up in a well-crafted statement.

The description of the Hub's defining characteristics, and proposals for the planning boundaries, must be included in the Status Quo Assessment Report.

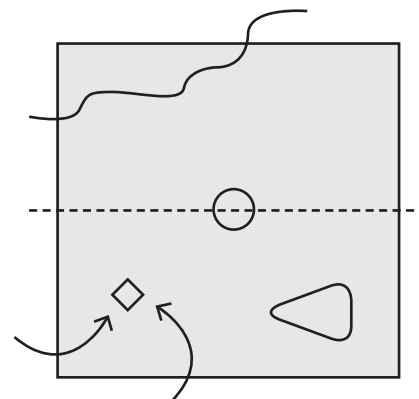
**STEPS**

- Analyse study area information obtained in Section 5.
- Prepare a Status Quo Assessment Report including characteristics of the future node.
- Confirm the boundaries of the Urban Hub.

**TOOLS**

Use the maps and data gathered in Section 5 to prepare the analysis.

Figure 5: Map indicating opportunities, constraints and challenges





EVALUATION

Refer to the STATUS QUO REPORT section of the Evaluation Guide (Section 19) for evaluation criteria.



The public will need to be strategically involved at specific points during the planning and design process. Input will be agreed upon between the NDP and the Municipality once a Work Plan has been finalised.

URBAN HUB DESIGN TOOLKIT

THE MUNICIPAL GUIDE: *Getting your hub started*

B. PRODUCE ACCESS AND MOVEMENT FRAMEWORK

7. Consider Hub to City Connectivity
8. Apply the Interchange Zone Concept
9. Make the Access Grid Visible
10. Locate the Pedestrian Ways
11. Consider Transport Infrastructure
12. Produce an Access and Movement Framework

7. CONSIDER HUB TO CITY CONNECTIVITY



OBJECTIVE

To identify what the main public transport intervention should be to achieve seamless connectivity between the local area and the broader city network.

The goal of this and the next task is to improve door-to-door connectivity across the city area for those without access to private transport.



STEPS

- The first step is to characterise the typology of the existing public transport linkages between the Urban Hub and the city area, in order to understand the implications for spatial integration and movement within the Hub.
- Develop a proposal for strengthening the connection between the Hub and the city if necessary.
- This task also involves identifying the order of magnitude of interventions needed for public transport infrastructure improvements.

Urban Hub public transport arrangements (existing and proposed) can usually be described in terms of one of three main typologies (see diagrams on next page). Rail is the dominant mode in Typologies 1 and 2. Although the rail line itself is a barrier to movement, station buildings create effective links over the line and therefore present opportunities for spatial integration. Typology 3, which relies on bus or taxi services, requires accommodation of a greater number of vehicles within the Urban Hub and attention needs to be given to the challenges associated with the scale and form of associated roadways.

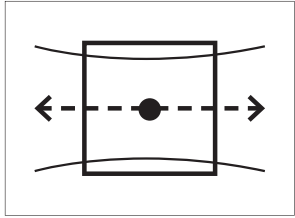


national treasury

Department:
National Treasury
REPUBLIC OF SOUTH AFRICA



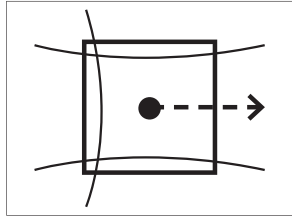
CREATING URBAN NETWORKS.
RESHAPING SOUTH AFRICA'S CITIES.



Typology 1:
 Rail Station as one of a number of points along a rail route.

Example: Khayelitsha

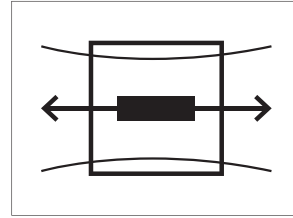
An existing or proposed rail line with a station feeding road based public transport services running parallel to the rail line.



Typology 2:
 Rail Station as end point of rail route

Example: Bridge City

An existing or new rail line with end station, feeding road based public transport services running parallel and or perpendicular to the rail line.

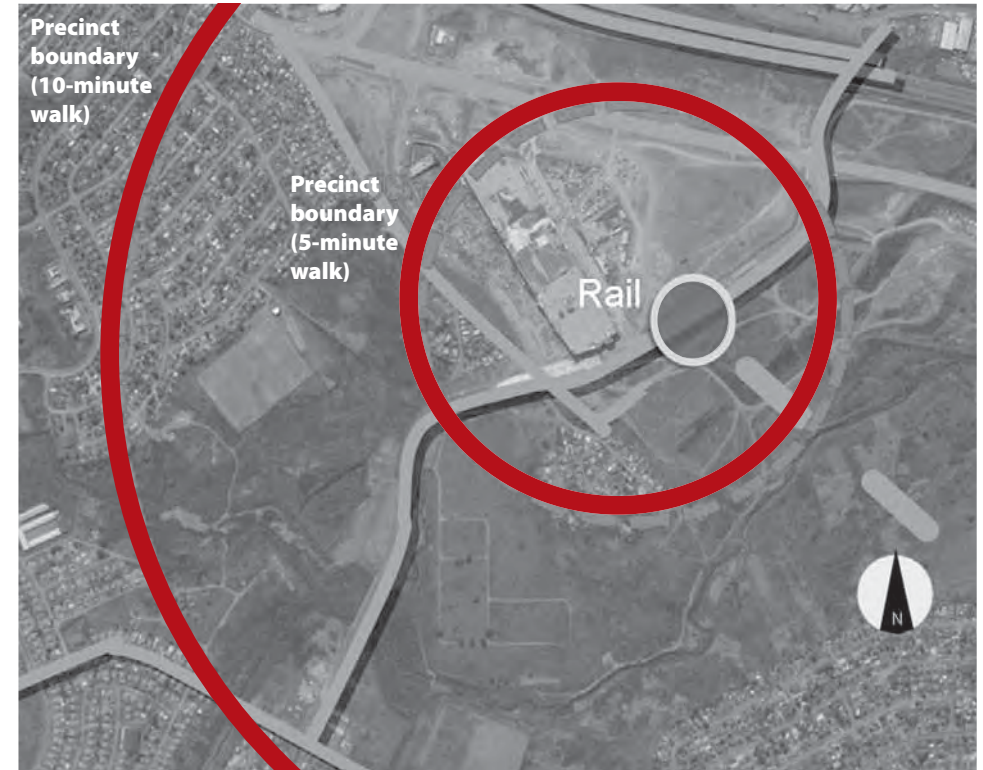



Typology 3:
 Public Transport route without support of rail

Example: Orlando Ekhaya

A new or existing public transport carrying route feeding other local road based public transport networks

Figure 6: Aerial Photograph of Bridge City which demonstrates Typology 2





TOOLS
 Use the access and transport analysis in the Status Quo Assessment Report to inform this task.

8. APPLY THE INTERCHANGE ZONE CONCEPT



OBJECTIVE

To develop a proposal for a pedestrian-friendly Interchange Zone for the Urban Hub and strengthen its connectivity into the local area.

WHAT IS AN INTERCHANGE ZONE?

An Interchange Zone is a point at which a number of public transport services meet, thus creating a point of high convergence and transfer of people. For this reason they hold enormous potential.

To understand where and how other land uses (e.g. commercial) can best make use of this opportunity, one needs to understand the Interchange Zone as a set of three related areas:

- areas of decision,
- movement, and
- opportunity.

The areas of decision are at the gates and ticket sales areas. The areas of movement are the spaces through and along which people must move to access the points of entry and exit onto the public transport networks. The edges of these areas of movement have potential to become areas of opportunity. Retail and service-related businesses will locate along these movement routes to increase the levels of convenience for users of public transport.

With good design, the interface formed by the areas of movement and areas of opportunity will ensure that the Interchange Zone becomes a destination in its own right as a vibrant hub of activity.

The Interchange Zone also needs to accommodate residential accommodation, cultural and recreational facilities in order to extend its hours of activity and optimise on the opportunities for people to reduce the distances between their places of residence, work and play. The Interchange Zone must offer all the basic amenities, services and qualities necessary to service the needs of public transport users, including good way-finding, lighting, ablutions, safety, security, and a sense of place.

Figure 7: Public space linking public transport facilities and commercial areas
(Stratford Interchange, UK) www.tfl.gov.uk/microsites/interchange/94



Figure 8: Street vending enlivening links between public transport facilities
(Warwick Triangle). Dennis Gilbert, www.informalcity.co.za





STEPS

- Confirm Interchange Zone area (accessibility zone of 400 metres).
- Identify main existing components of Interchange Zone (Use Section 7 for this).
- Determine required components/infrastructure taking pedestrian movement, connectivity and other related areas into consideration.

This task focuses on improving connectivity within the Hub by designing an Interchange Zone in which road and rail based public transport services come together within easy walking distance of one other.

By applying the Interchange Zone concept in the creation of a pedestrian-friendly transit environment, opportunities for commercial operators are established through the strategic separation of different modes of public transport services, causing large numbers of people to converge at points or along a route.

The separation between rail, bus and taxi stations should not be more than 150 to 200 metres (2 to 3 minutes of walking). The main components of the Interchange Zone should be located within an accessibility zone described by a 400 metre radius.

The Interchange Zone in turn needs to be connected to the areas surrounding the Hub by a network of vehicular and non-motorised transport linkages.



TOOLS

Use the preceding task to inform the proposal.

Use the status quo assessment of:

- access and transport analysis;
- Existing public transport services and stops;
- Connection via public transport modes with broader area to inform this task.

Figure 9: Aerial photograph of Mitchell's Plain town centre, showing application of the Interchange Zone concept



9. MAKE THE ACCESS GRID VISIBLE



OBJECTIVE

To clarify scale and alignment of public movement routes.

The network of routes across the Urban Hub must be scaled to allow easy pedestrian movement in tandem with easy public transportation services.

A rectilinear, multi-directional network, or grid, supports an even permeability for both cars and people across an area. Rectangular blocks of 50 to 60 metres wide and 150 to 200 metres long have worked successfully all over the world, although blocks longer than 60 metres can be problematic in commercial precincts because they limit permeability for pedestrians.

It is important to note that a grid is inevitably warped to respond to topography, natural features and fixed infrastructure etc.



STEPS

- Prepare a scaled plan of the Urban Hub.
- Overlay the access grid and the status quo assessment of the key barriers to movement.
- Demonstrate where connectivity will be restricted and which points within the grid will represent opportunities.

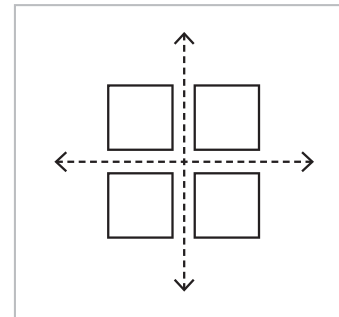


TOOLS

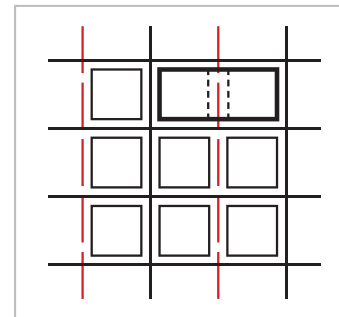
Use the status quo assessment of :

- the key barriers to movement;
- hierarchy of roads and list class of roads; and
- transport planning proposals for the area

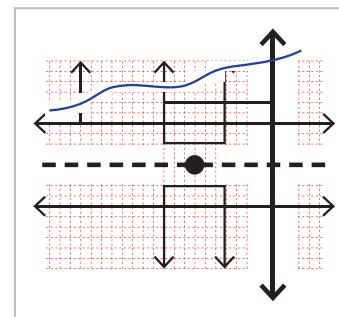
Figure 10: Development of the Access Grid



60 X 60
PEDESTRIAN BLOCK



60 X 120
VEHICULAR
ORIENTATED BLOCK




GRID RESPONDING
TO SITE INFORMANTS

10. LOCATE THE PEDESTRIAN WAYS


 **OBJECTIVE**
To identify the main pedestrian connections.

The Urban Hubs will ideally be pedestrianised zones within which people will have no need for a car. The entire movement network, including any roads, should be pedestrian-friendly and integrated within the broader open space system.

Roads should be designed so that it is always clear that pedestrians are the 'dominant' users. Sidewalks should be generous and road crossings, generous and frequent. Roads should have the same feeling as public open space, rather than conduits for traffic. Where land use activity intensifies or pulses along routes, increased levels of cross movement must be facilitated and the linear focus of development interrupted to form a space.

 **STEPS**
Identify priority routes in order to maximise commercial opportunities and passive surveillance.
These are likely to be the pedestrian routes that link strategic facilities and amenities within the Hub.

This Prioritised Pedestrian Network, as part of the Public Space Network, must be developed as a series of landscaped links and spaces which will extend over time, as development unfolds, beyond the limits of the Interchange Zone.

 **TOOLS**
Use the following status quo information:

- Pedestrian and cycling movement patterns; and
- The key barriers to movement.

Figure 11: A Vibrant Pedestrian Route in Mitchells Plain Town Centre.



11. CONSIDER TRANSPORT INFRASTRUCTURE



OBJECTIVE

To identify the approximate size and capacity of transport infrastructure required within the Hub.

The form and spatial quality of transport infrastructure affects performance of the urban environment. Land use alongside roadways, in particular, is often dictated by the type of road. Design must focus on creating people-friendly spaces within the Urban Hub, and modifications and/or upgrading of existing infrastructure may be necessary in order to achieve the objectives.

Road networks will be comprised of a hierarchy of routes connecting at different scales, including those belonging to the public transport networks surrounding the Hub. Where a high order speed road (primary network connector) unavoidably passes through the Urban Hub, it should be pinched to slow traffic and allow greater levels of transfer and interaction. Secondary network connector routes, on the other hand, typically carry high-frequency public transport services which are stop-start in nature, which can work well within a Hub to attract a mix of land uses and intense pedestrian activity along their length. Local routes should accommodate cyclists and pedestrians and, overall, proposals must include associated facilities such as bus stops, road crossings and bicycle parking.

Whilst rail lines are effective metro-wide connectors, at the local level they are spatially divisive. Bridging across rail lines needs to be done at strategic points in a well-considered way, with attention to what is happening on both sides of the line. Rail stations are the most obvious locations for bridging and for maximising opportunities associated with large numbers of people crossing the line.



TOOLS

- Previous steps within this document.
- Use existing transport standards and benchmarks to determine the size and capacity of transport infrastructure.

Figure 12: A Modern Public Transport Interchange which hosts rail, bus and taxi services – a facility supporting other land uses and creating people friendly spaces.



12. PRODUCE AN ACCESS AND MOVEMENT FRAMEWORK

OBJECTIVE

To consolidate proposals for movement systems within the Urban Hub.

An Access and Movement Framework is a planning instrument comprising spatial plans and reports that collectively demonstrate:

- Application of the Interchange Zone concept and Access Grid. (This will ensure that the plan is appropriately scaled for pedestrians and facilitates optimal transportation flows and servicing).
- The Prioritised Pedestrian Network and other mechanisms for achieving and/or improving pedestrian connectivity.
- How the various public transport services, including non-motorised transport, will be aligned and relate to each other.
- In the case of a brownfields site, an assessment of the existing access network relative to the Interchange Zone concept and the need to focus on pedestrians.
- The capacity of existing and proposed public transport facilities and services and identification of new and/or upgraded infrastructure projects.
- How key private transport linkages, including commercial goods transfer and emergency services, can be accommodated.

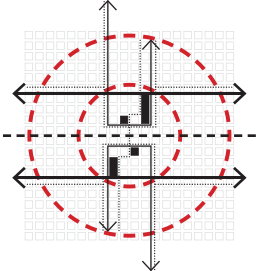
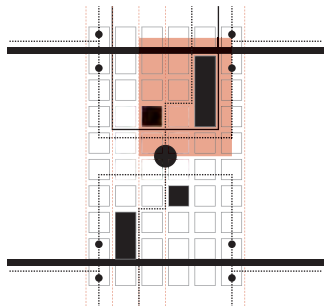
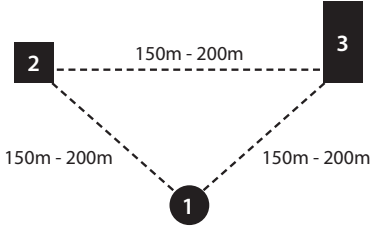
TOOLS

- Previous steps within this document.
- Use existing transport standards and benchmarks to determine the size and capacity of transport infrastructure.

EVALUATION

Refer to the ACCESS AND MOVEMENT FRAMEWORK section of the Evaluation Guide (Section 19) for evaluation criteria.

Figure 13: Stages in development of an Access and Movement Network



Apply Interchange Concept



Make Access Grid and Local Pedestrian Ways



Consider Transport Infrastructure

URBAN HUB DESIGN TOOLKIT

THE MUNICIPAL GUIDE: *Getting your hub started*

C. PREPARE LAND USE FRAMEWORK

13. Identify Conceptual Zones
14. Consider Housing Typologies
15. Identify and Locate the Main Land Uses

13. CONCEPTUAL LAND USE ZONES



OBJECTIVE

To establish broad land use zones within the Urban Hub precinct.

The Urban Hub can be conceptualised as a set of three interdependent land use character zones that relate to different components of the public transport network.

- The Heart corresponds to the Interchange Zone and the 400m accessibility zone.
- The Active Corridor Zones correspond to the public transport corridors that pass through the Hub.
- The Transition Zones are the remaining areas that do not relate to any higher order public transport service or route and will mostly lie within the 800m of the main city public transport service point.

The Zones do not have defined boundaries and will overlap in places and cross the accessibility radii. Conceptualising the hub in this way is a tool, and not intended to be used prescriptively to define development precincts or land use.



TOOLS

Use Status Quo Assessment Report to inform this task:

- Planning and regulatory environment; and
- Land use patterns.
- Consider Access and Movement Framework.
- Refer to the Practitioner`s Manual for detailed guidance.

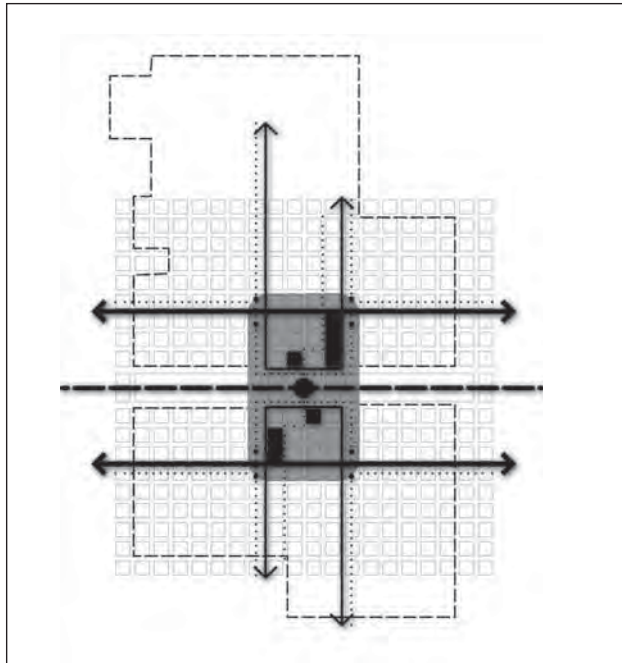


national treasury

Department:
National Treasury
REPUBLIC OF SOUTH AFRICA

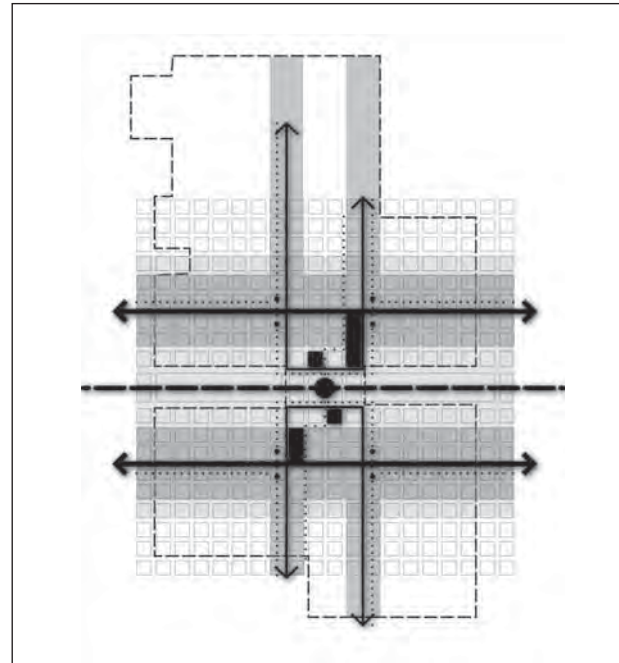


Figure 14: Conceptual Land Use Zones



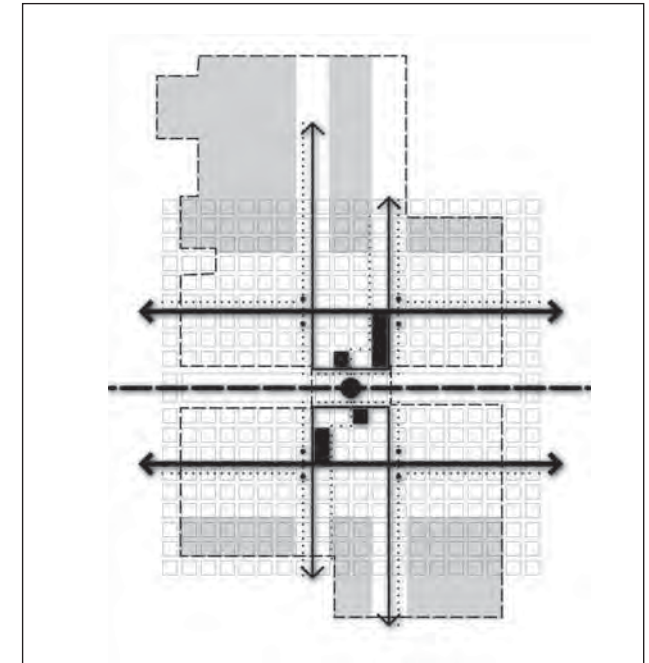
THE HEART

Central, most public, most dense and most intense area within Hub. Key destinations to be located here.



THE ACTIVE CORRIDOR ZONES

Relate to the Secondary and Primary Connectors into the Hub. Business and manufacturing will be permitted, but in specific locations only so as not to compromise the liveability of the area.



THE TRANSITIONAL ZONES

Intermediate zones between the Heart and the Active Corridor Zones. Least dense and least intense and accommodate the most land extensive of the activities.

14. CONSIDER HOUSING TYPOLOGIES



OBJECTIVE

To provisionally identify the housing typologies required to achieve the required densities.

The provision of public transport services and facilities requires that there are adequate numbers of people to make them viable. The value of facilities is optimised when there are people using them 24-7, which is why the Urban Hubs must include residential accommodation. This will also significantly contribute to the creation of a vibrant urban environment.

Fortunately, people find it convenient to live close to public transport hubs and it is therefore likely that housing stock within the Urban Hubs will be in demand. This mutually reinforcing relationship, between housing and public transport services, can be exploited to increase thresholds to a level that justifies the provision of desirable public facilities and amenities, and mobilises the private sector to invest in commercial and service ventures within the Hub.

Planners use population density to calculate an estimate of the optimum population of the Urban Hub, and population numbers that include the Hub's catchment area are used to determine the number of various types of facilities.

In order to calculate a Land Use Budget it is important to consider what housing typologies will be needed in order to generate the population numbers required to create a vibrant, urban living environment and viable public transport system. A range of accommodation types, income categories and forms of tenure is envisaged.

The Heart and Corridor Zones will typically attract smaller size units to optimise on places of highest accessibility. Larger units and less dense housing development will be best located in the Transition Zones.



STEPS

Calculate Land Use Budget based on land availability, densities, typologies and facilities required.



TOOLS

- Status Quo Report on housing typologies and densities, housing tenure, retail and business demand.
- Norms and Standards for housing densities and facilities.
- Refer to the Practitioner's Manual for detailed guidance.

Figure 15: Mixed use building with residential accommodation above shops



15. IDENTIFY AND LOCATE THE MAIN LAND USES



OBJECTIVE

To develop a concept for integrated mixed land use within the Urban Hub.

It is the intention that the Urban Hubs will introduce new models of development that enable the mixing of land uses, through horizontal and vertical integration of commercial, residential, transport and social facilities. Mixed use results in more efficient movement systems, land and resource utilisation, and lively urban environments. The particularities of the mix need to be informed by the character of the Urban Hub under consideration.

The Practitioner's Manual, available on the NDP website, provides detailed locational guidelines for public facilities and amenities, commercial (retail, office, industrial/manufacturing), residential and parking accommodation within the Urban Hub. They are designed to encourage application of the following principles:

- Maximise on thresholds generated by the integrated transport system
- Locate essential day-to-day destinations in the most accessible locations
- Support vertical and horizontal integration of different land uses
- Explore new forms of development that support mixed land use.

The Conceptual Land Use Framework should be understood as a set of layers where overlaps are essential to ensure integrated development. The Heart and Active Corridor zones should demonstrate the highest density of land use activity.



STEPS

- Overlay Transport and Movement Framework with Proposed Land Use Zones.
- Layer proposed land uses by using density and Land Use Budget results.
- Identify possible sub-precincts



TOOLS

- Refer to Status Quo Report on Land Use Patterns, Planning and Regulatory Environment, etc.
- Consider Access and Movement Framework.
- Refer to the Practitioner's Manual for detailed guidance.



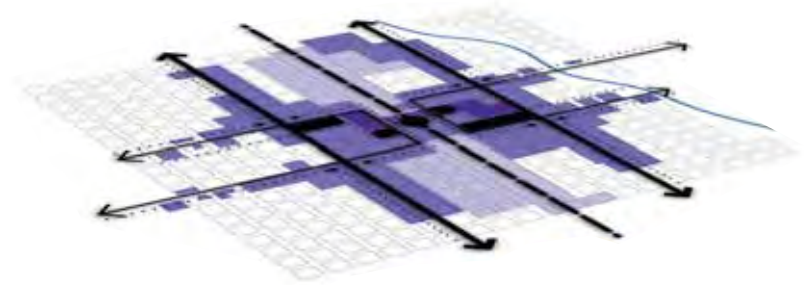
EVALUATION

Refer to the LAND USE FRAMEWORK section of the Evaluation Guide (Section 19) for evaluation criteria.

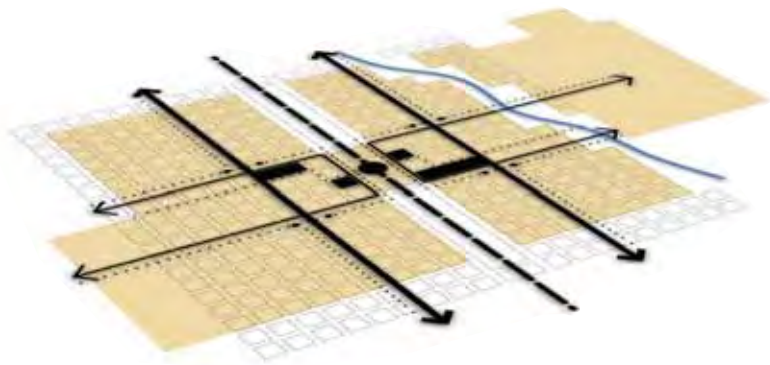
Figure 16: Land Use Layers that make up the Conceptual Land Use Framework



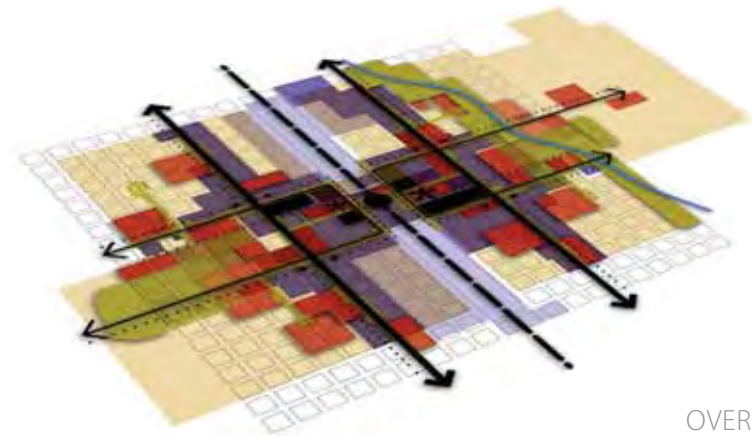
PUBLIC FACILITIES
AND GREEN AMENITIES



BUSINESS, RETAIL,
INDUSTRIAL



RESIDENTIAL



OVERLAY OF
LAND USES

URBAN HUB DESIGN TOOLKIT

THE MUNICIPAL GUIDE: *Getting your hub started*

D. CONCEPTUALISE THE FORM OF DEVELOPMENT

16. CONCEPTUALISE THE FORM OF DEVELOPMENT



OBJECTIVE

To Prepare conceptual Sub-Precinct Plans for smaller parts of the Hub that identify how the urban blocks, streets and public spaces will be laid out.

The planning and design process, available on the NDP website, moves into a more detailed, sub-precinct scale with this task, which focuses on the urban blocks and spaces between them. It focuses on the form of the urban blocks and how best to accommodate the required mix of land uses to create a more vibrant, pedestrian-orientated environment. It is also the scale at which the streets and public spaces, as a container of urban public life, start being conceptualised. The interfaces between buildings and streets and public spaces must be well considered in terms of:

- Definition or enclosure of public outdoor spaces, which can provide both psychological and physical comfort;
- Scale of buildings and open spaces relative to a person on foot, which also affects psychological well-being;
- Diversity of occupancies along street edges and public spaces, affording vibrancy and extended periods of activity;
- Adaptability and capacity to adapt over time to accommodate changes in use or in levels of occupancy
- Compaction and integration of land use activities and diverse user groups, which is essential to creating a vibrant urban environment; and
- Legibility of the built environment, making it easy for people to find their destinations and routes.

DELIVERABLES RELATED TO THE SCALE OF THE SUB-PRECINCT

- a. Sub-Precinct Plans, showing 1.) development parcels in relation to detailed proposals for infrastructure (roads, non-motorised transport paths, transport and services) and 2.) bulk breakdowns to guide future planning processes. The Bulk breakdowns will consider parking take up and take into account the vertical layering of land uses.

Urban Design Framework including explanations of key interface conditions and design guidelines (with specifications if necessary) to assist in providing direction in the making of the public realm.



national treasury

Department:
National Treasury
REPUBLIC OF SOUTH AFRICA





Note Sub-precincts are to be defined in terms of phasing preferences or in terms of functional areas e.g. an area related to a key focal point/area such as the interchange Zone, or a linear system such as an activity street.



STEPS

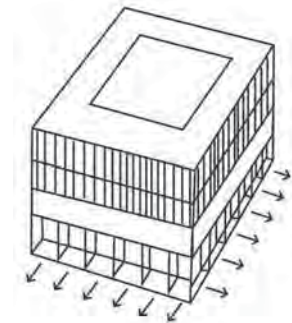
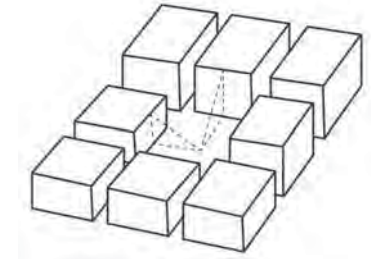
- Identify Sub-Precincts.
- Confirm Sub-Precinct boundaries.
- Identify detailed design objectives and principles for each Sub-Precinct.
- Conceptualise design components and layers.



EVALUATION

Refer to the PRECINCT AND SUB-PRECINCT section of the Evaluation Guide (Section 19) for evaluation criteria.

Figure 17: Illustrations of Key Urban Design Principles



URBAN HUB DESIGN TOOLKIT

THE MUNICIPAL GUIDE: *Getting your hub started*

E. DEVELOP PLACE-MAKING GUIDELINES

17. DEVELOP PLACE-MAKING GUIDELINES



OBJECTIVE

To prepare detailed guidelines, specifications and Urban Design Frameworks for the Public Space Network and the design of individual buildings that line these routes.

The Public Space Network comprises the public spaces and routes that form a connected whole and facilitate seamless movement between key destinations and places within an area. Good design has the potential to turn these spaces into vibrant pedestrian precincts which, in turn, translates into economic returns for investors and heightened experiential value for the users.

Whilst there may continue to be some direct involvement in landscape design on municipal-owned property, the role of Urban Hub development managers shifts significantly at the implementation stage, from one of direct oversight to one of providing guidance and review for the design of the buildings that will form the urban blocks. The interfaces, formed by the edges of the buildings that enclose or frame the public spaces and places within the Hub, are key because they have a direct effect on the experience of the people using the Public Space Network.



national treasury

Department:
National Treasury
REPUBLIC OF SOUTH AFRICA



In order to guide this important work, Urban Hub development managers must develop guidelines and specifications that can be issued as briefing documents to all developers and public sector agents who become involved in infrastructure delivery within the Hub (e.g. Public Works, Education, Health, Roads and Transportation). Urban Hub development managers also need to ensure that the various agencies have a good understanding of their respective responsibilities, particularly regarding landscaping, and must have the opportunity to review proposals at strategic stages of design development.

The particular character of the Urban Hub, as articulated in terms of Section A, should be strengthened and made tangible through these details. Transparency, detail, depth and modulation, and climate responsiveness are features that need to be present in design proposals for the interface edge of buildings that border the Public Space Network.

For people to easily find their way through the Public Space Network, the landscaping of Prioritised Pedestrian routes should appear consistent. The Urban Design Frameworks must include landscaping guidelines and specifications for each Urban Hub to suit its character and environmental conditions. The Practitioner's Manual provides generic guidelines for tree planting, grass, low planting, paving, bins, lighting, signage, seating, bollards, bike racks, art and sculpture, toilets and water points. These can be used as a starting point for Hub-specific guidelines and specifications.



STEPS

- Confirm objectives and principles for place-making.
- Develop design guidelines and specifications.
- Review and align statutory processes and documentation where possible.



TOOLS

- Refer to the Practitioner's Manual for detailed guidance.



EVALUATION

Briefing documents for buildings that abut the Public Space Network must include Urban Design Frameworks for the Urban Hub or, if applicable, its sub-precincts.

URBAN HUB DESIGN TOOLKIT

THE MUNICIPAL GUIDE: *Getting your hub started*

F. DEVELOP A PHASING PLAN

18. DEVELOP A PHASING PLAN



OBJECTIVE

To consider an implementation phasing strategy.

The Neighbourhood Development Programme aims to leverage private sector investment in the Urban Hubs by using public funds to lay down certain components which create an environment conducive to private sector development. Developers may initially be resistant to the innovations being introduced and the municipality will need to take a strong lead. It should be made clear upfront that the objectives of creating more urban, quality environments will be pursued through the State's involvement, acting in the interest of the broader public, and that ultimately developers will benefit from this through a broadening market.

The spatial phasing and roll-out of development of the Hubs is a critical aspect of ensuring their viability and sustainability. Institutional arrangements, land ownership and release, and municipal revenue requirements all impact on the phasing approach. An 'ideal' four-step approach is presented that would need to be adapted to suit each Hub, dependant on its stage of development and funding available. In the four-steps approach, it's assumed that the Access and Movement Framework and Conceptual Land Use Framework have already been prepared. This would ensure that key elements of the proposed urban structure are fixed from an early stage and form a robust and legible framework, on to which future development can clip.

The following principles should be applied in adaptation of the four-steps approach to suit a particular Urban Hub:

- The phasing plan must demonstrate to the private sector that the public sector is committed and on board.
- The phasing plan must fix non-negotiable elements through construction of new or upgraded PT facilities and access routes.
- The phasing plan must focus on connecting the Hub to the metro network and local access network simultaneously to ensure integration of new development. Where rail stations are upgraded, non-motorised transport linkages between the stations and the local areas should be implemented simultaneously.



national treasury


Department:
National Treasury
REPUBLIC OF SOUTH AFRICA




- The phasing plan must ensure all non-motorised transport routes are framed by development from the outset. The edges can be phased themselves if they are conceptualised as colonnades that get filled in over time.
- The first phases of development should always attempt to create a 'complete system', i.e. a network that connects key generators of movement and destinations.

Irrespective of the implementation strategy, the municipality must take a proactive pro-poor approach to urban land governance and facilitate integrated solutions that will require different departments within the municipality and spheres of government to work together. It is critical that all departments, individuals and spheres share a common set of objectives and set reasonable and strategic time frames. The respective phases may have different objectives but the overall intent of the NDP must be the single biggest informant.

The diagram overleaf demonstrates hypothetically how these four steps may be applied in the development of Khayelitsha Town Centre.



Note that the aim will be to develop a Precinct Plan for the Urban Hub based on the design framework. This Precinct Plan should contain detailed information regarding projects to be implemented and should be prioritised with a time line for implementation. Refer to the Urban Networks Support Guide for more information on the Precinct Plan requirements.



TOOLS

- Use the Land Use Framework and Access and Movement Framework to inform the Phasing Plan.
- Refer to the Practitioner's Manual for detailed guidance.

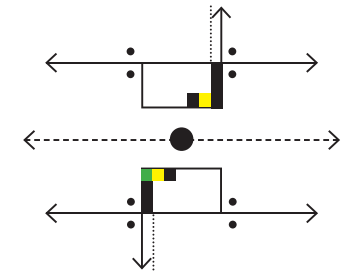
PHASE 1 STEPS

Focus public funding on the construction or upgrade of rail infrastructure and/or higher order road based infrastructure (such as a BRT) linking the Hub to the broader metro area, followed by other Public Transport facilities within the proposed Interchange Zone that will connect the main Public Transport service to a local road based service. Ensure that the pedestrian linkage between the rail and the road based Public Transport service facility is established and is framed by an active interface. This should ideally be the first stage of private sector involvement.



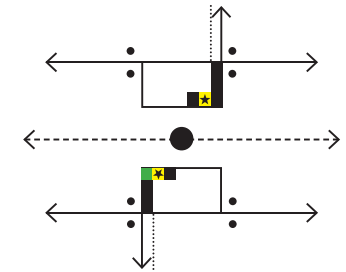
PHASE 2 STEPS

Focus, and where possible private, funding on the construction of minimal road linkages to connect the Hub with fine scaled local road network and new public facilities that can help to create a sense of place. Simultaneously construct remaining Public Transport facilities required to create integrated system of services. The implementation of building facilities other than transport facilities (roads and rail) in phase 2 should be carefully planned not to have an over congested "site" in respect of construction.



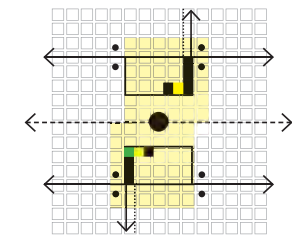
PHASE 3 STEPS

Incentivise private sector to invest in development of integrated mixed use precincts within the Interchange Zone, ensuring delivery of a mix of commercial, public / institutional and residential land uses. Developments should incorporate large public anchors such as regional and or district scale facilities/amenities.



PHASE 4 STEPS

Focus public funds on the extension of the Hub access network with a focus on components of the prioritised public space network and the Corridors and service land ready for more private sector development. Continue to invest in spaces and social facilities in strategic locations within the Hub.

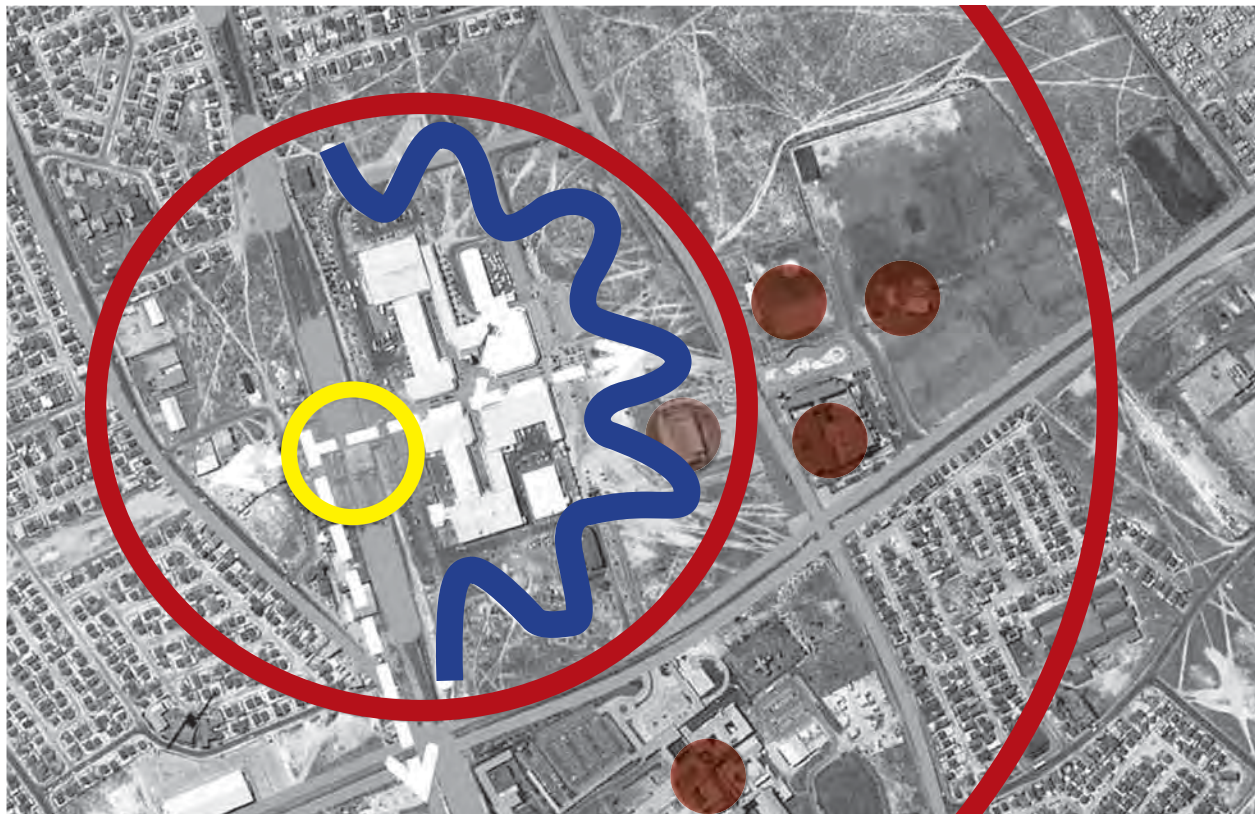


18. DEVELOP A PHASING PLAN - continued

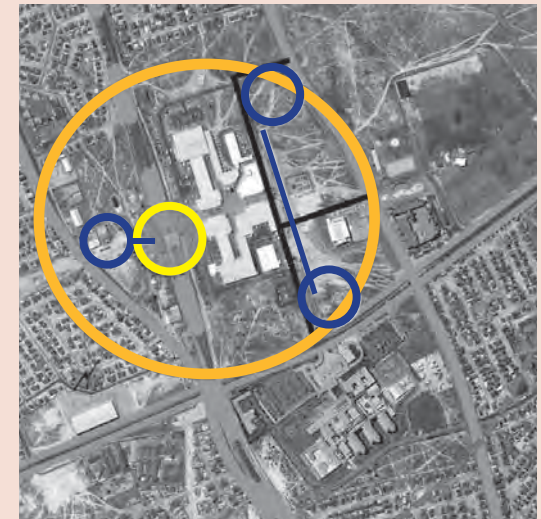
HYPOTHETICAL EXAMPLE OF THE FOUR STEP PHASING APPROACH: GETTING IT RIGHT

PROBLEM STATEMENT

Underexploited linkages between the rail station (yellow) and other, poorly defined public transport points.
Poor connectivity between the Hub and other public facilities (maroon).

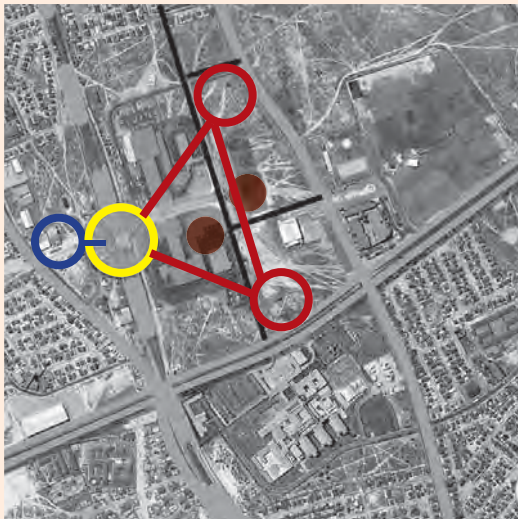


STEP 1



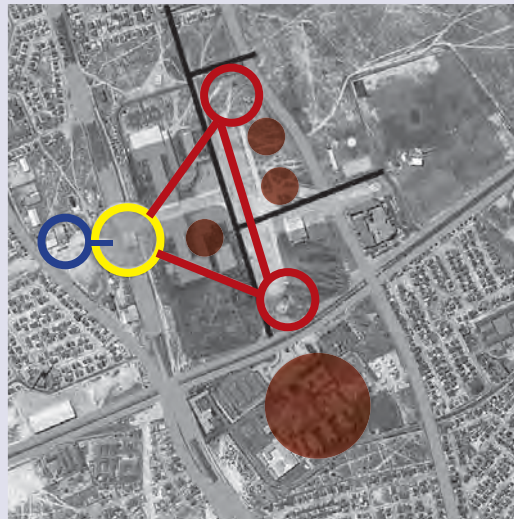
Public funding used to strengthen public transport services, introduce new modal points (blue) and new local roads (black) within the Interchange Zone.

STEP 2



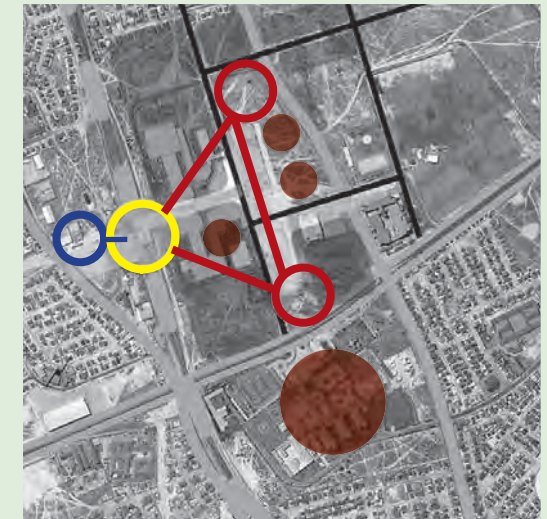
Strong pedestrian linkage (red) established between two modal points, attracting private sector development (maroon) or occupation along this route. Public funding invested in completion of an integrated public transport system and expansion of pedestrian linkages to activate the Interchange Zone.

STEP 3



New social facility (maroon), extension of new roads to connect into the local neighbourhood. Private sector responds to incentives, mixed use development aggregates around public transport facilities and pedestrian linkages.

STEP 4



Public funding used to strengthen the Public Space Network and develop further public facilities in the transition zones. Local road and Public Space Network extended into undeveloped transition areas, to open up new areas for private sector development and new or upgraded social facilities and amenities.

URBAN HUB DESIGN TOOLKIT

THE MUNICIPAL GUIDE: *Getting your hub started*

EVALUATION GUIDE

1. Status Quo Report
2. Access and Movement Framework
3. Land Use Framework
4. Precinct Plans
5. Sub-Precinct Plans

19. EVALUATION GUIDE

Neighbourhood Development Programme

URBAN HUB DESIGN TOOLKIT

THE MUNICIPAL GUIDE: *Getting your hub started*

A

STATUS QUO REPORT

- Are the following included:
 - Identification of environmental needs; and
 - Identification of social and economic needs?
- Spatial synthesis that identifies major opportunities and constraints
- Is there a provisional understanding of the extent of the Hub to be the subject of this exercise (greenfields and brownfields)?
- Is there a description of the character of the node, now and into the future?

B

ACCESS AND MOVEMENT FRAMEWORK

- Does the road network respond to the topography?
- Are the urban blocks proportioned appropriately so as to allow a set of transport services to operate efficiently as one integrated system?
- Can people find / orientate themselves easily by referencing off topographical features and a hierarchical logic in the network?
- Has the proposed network addressed the challenges presented by major linear forms of infrastructure (rail lines) and/or topographical features (rivers) which prevent seamless connections for those on foot?
- Does the network locate the main bus, taxi and rail/BRT facilities within walkable distance of each other?
- Does the network provide for a set of continuous local road and non-motorised transport connections between the Interchange Zone and the Hub surrounds?
- Do the strategies supporting the framework address the scale of the roads to allow for the correct balance of pedestrian to vehicular needs to be met in strategic locations and zones?
- Does the Access and Movement Framework link with the larger urban network?

C

LAND USE FRAMEWORK

- Can the most accessible and visible locations accommodate street vending?
 - Does the layout allow large commercial anchor tenants to be located strategically in support of smaller scale operators including street vendors?
 - Does the layout allow commercial activity to agglomerate in relation to activity routes and the Interchange Zone?
 - Is there a mix of land uses to extend hours of activity (beyond standard work day hours) at strategic points in the hub such as within the Interchange Zone and Activity Corridors?
 - Are SAPS facilities located so as to be visible and accessible to main commuter flows?
 - Do the routes within the Prioritised Pedestrian Network link key public destinations?
 - Are the public institutions, facilities, amenities and services clustered where possible?
- Are land uses such as manufacturing located to ensure residents are not exposed to harmful noise levels, fumes etc.?
 - Are the green open spaces located in relation to the topography in such a way as to help storm water management?
 - Does the layout allow significant historical and cultural linkages to be maintained and strengthened? The Public Space Network should reinforce the critical linkages.
 - Does the framework consider current and proposed zoning?
 - Does the land use budget consider industry standards and the needs of the community?
 - Have housing typologies and densities been considered?
 - Are the neighbouring land uses proposed within the hub areas compatible?

19. EVALUATION GUIDE - continued

Neighbourhood Development Programme

URBAN HUB DESIGN TOOLKIT

THE MUNICIPAL GUIDE: *Getting your hub started*

D

PRECINCT PLANS

- Are pedestrian routes at grade as far as possible?
 - Are the main public spaces and routes clearly defined and distinctive?
 - Are there any dead zones at the scale of the whole? For example are there any large expanses of vacant land, large 'un-activated' landscaped areas, public streets with no overlooking features or active interfaces that people are reliant on, on a daily basis to access home, work or shopping, play?
 - Are the key spaces and routes edged by appropriately scaled buildings?
 - Are the development envelopes scaled to allow fine grained pedestrian movement across the Hub? Do the key social facilities / institutions have large public spaces/forecourts into which the public programmes can spill over and overlap?
- Are street traders exposed to the highest pedestrian thresholds in the Hub?
 - Do the levels above ground along routes within the Prioritised Pedestrian Network accommodate the type of land use that could offer passive surveillance over the public domain?
 - Does the Precinct layout allow for the clustering of potentially compatible facilities / services?
 - Does the Precinct Layout allow for the agglomeration of similar commercial / business type activities
 - Are the spaces and streets scaled appropriately for those on foot?
 - Do the plans propose a range of activities at ground floor and above to activate those routes used by commuters in the early evening and morning hours?



SUB-PRECINCT PLANS

- Are the pavements generous enough to accommodate the required pedestrian flows? (Pedestrian routes should have a clear width of a minimum of 2 metres)
 - Are the ground floor interfaces sufficiently detailed and appropriately scaled to encourage people to pause, linger and engage with what is on display?
 - Is there a common language of design within the main public spaces that comprise the Public Space Network?
 - Is there sufficient lighting within the Sub-Precinct and, in particular, the spaces and streets within the Prioritised Pedestrian Network?
 - Are the ground floor interfaces going to be sufficiently transparent and interactive to allow surveillance of the streets and public spaces within the Prioritised Pedestrian Network?
 - Does the architecture respond appropriately to the climatic conditions?
 - Do the levels above ground along the key public routes have overlooking features encouraging occupants to have their eyes on the street?
- Where pedestrians are channelled through subways, are they generous, well lit and activated with commercial activities as well as universally accessible?
 - Where pedestrians are channelled over the rail line via bridges, are they generous, well lit and activated with commercial activities as well as universally accessible?
 - Are the critical access routes to and between the various modes of transport universally accessible?
 - Are the public spaces and routes orientated optimally as far as possible and sufficiently enclosed to protect from dominant winds?
 - Are there opportunities for commuters to seek some level of refuge from the rain and sun when moving between the main PT interchanges and stops, stations?
 - Are there spaces within the Public Space Network that can accommodate special events that don't detrimentally affect pedestrian and traffic flows?
 - Are roads that handle large volumes of parallel and perpendicular pedestrian movement designed to prioritise pedestrians?
- Are the proposed landscaping materials robust enough that they require only limited and simple maintenance?
 - Are street elements such as seating, refuse bins, lighting etc. designed for easy replicability?
 - Does tree planting create shade in well-utilised public spaces and cast shadows across warmer building interfaces?
 - Is tree planting utilised in public parking areas to lessen the visual impact?
 - Is tree planting utilised in large hard surfaced areas to reduce heat build-up?
 - Are public bins located to allow for easy collection and recycling strategies to be implemented?
 - Are plant materials low maintenance and water-wise?
 - Is planting grouped to facilitate easy irrigation arrangements?
 - Are irrigation systems designed to reduce excessive water evaporation?
 - Is street furniture placed so as not to restrict critical pedestrian flows?
 - Is seating and lighting positioned optimally to allow increased levels of engagement between people?

URBAN HUB DESIGN TOOLKIT

THE MUNICIPAL GUIDE: *Getting your hub started*

20. DEFINITIONS AND ACRONYMS

20. DEFINITIONS AND ACRONYMS

| | |
|-------------------------------|--|
| ACCESS AND MOVEMENT FRAMEWORK | This is a framework plan that illustrates diagrammatically, in plan view, how the access and movement infrastructure is aligned, and is accompanied by descriptions of the capacity of the public transport facilities. It will also talk to the nature of the linear infrastructural links. |
| ACCESS AND MOVEMENT NETWORK | The network of infrastructural links which facilitate movement of people and cars. Where this network is referred to in the document it refers specifically to the network within the Hub only. |
| ACCESSIBILITY ZONES | Walkable 400 and 800m catchments related to facilities supporting road based forms of Public transport and rail stations respectively. |
| ACTIVITY ROUTE | A route characterized by strip and/or nodal urban development along portions of the route. They are generally supported by a mix of land uses and higher density development. public transport feeder routes connect with the activity routes at frequent intervals. Feeder routes and public transport stops interrupt the movement flows, creating opportunities for social and economic activities. |
| BRT | Bus Rapid Transport |
| CBD | Central Business District |
| CONCEPTUAL LAND USE FRAMEWORK | This Framework comprises a plan that provisionally locates the proposed land uses in relation to the access network. The framework is accompanied by a high level land use breakdown in which the proposed commercial bulk, residential densities, public facilities, services and amenities for the Hub are described. |
| GROSS BASE DENSITY | The average number of dwelling units per hectare across large city areas or the whole city, excluding land-extensive uses such as agriculture and conservation. |
| GROSS DENSITY | The number of dwelling units per hectare of land calculated over a specified area on the basis of land used for residential purposes and other land uses such as roads, utilities, business, industry, education, transport and parks. Land-extensive land uses such as agriculture, conservation etc. are excluded. |



national treasury

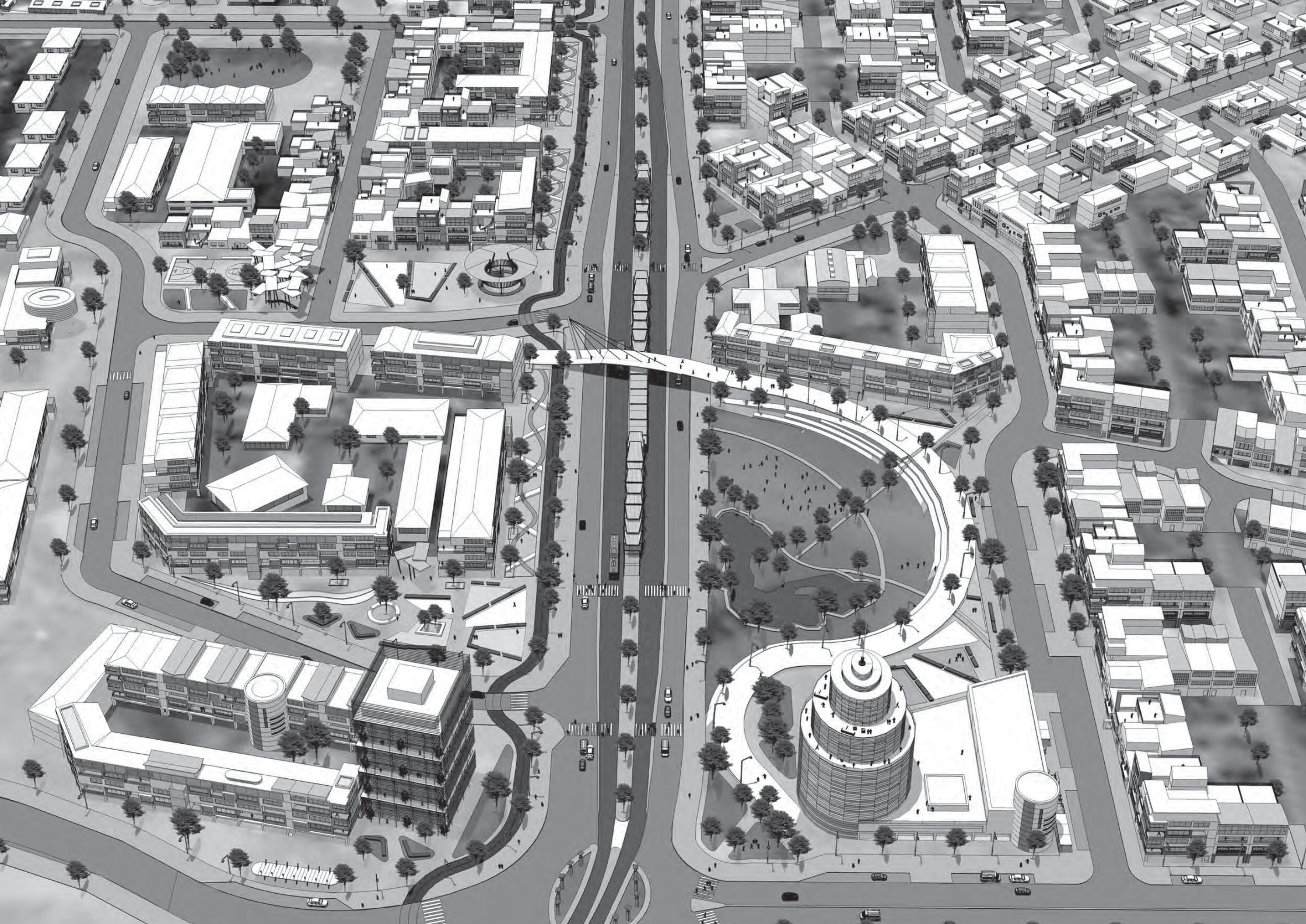
Department:
National Treasury
REPUBLIC OF SOUTH AFRICA



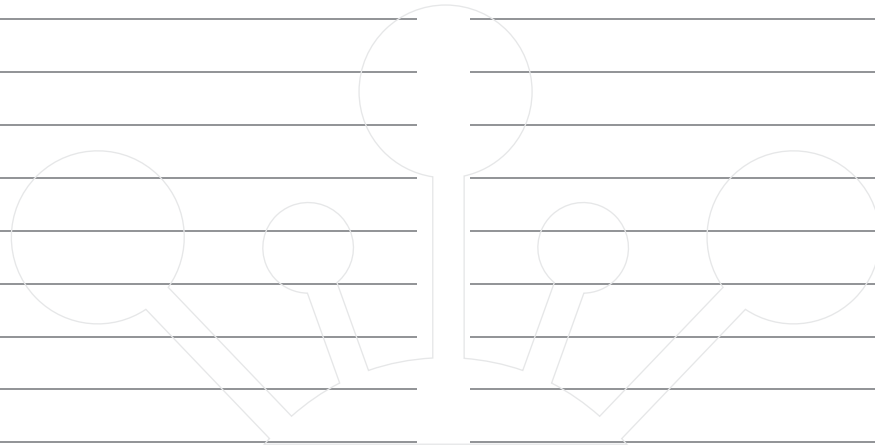
CREATING URBAN NETWORKS.
RESHAPING SOUTH AFRICA'S CITIES.

| | |
|---------------------------------------|---|
| GUIDELINES | Guidelines set broad parameters in which designers and planners can operate to meet particular objectives. They allow for levels of flexibility sufficient to respond to contextual variances. |
| HUB | Refer to "Urban Hub" definition. |
| INTERCHANGE ZONE | An interchange is where the transport services meet and includes not only the facilities where interchange happens but also the environment between these facilities that collectively operate as a large system of connectivity. The Interchange Zone will allow feeder public transport services, pedestrians and other dominant forms of non-motorised transport opportunities to connect to the higher order metro wide public transport network. |
| LOCAL NETWORK | The network at the scale of the Hub and its immediate surrounds. Local connectors will link the Hub to its immediate surrounds. |
| NDP | Neighbourhood Development Programme |
| NETT DENSITY | The number of dwelling units per hectare of land calculated on the basis of land used for residential purposes only (including residential gardens and privatised off-street parking). |
| POPULATION DENSITY | Number of people per hectare calculated by multiplying the number of units by a contextually relevant average household size. |
| PRIMARY NETWORK | The primary network is at city-wide scale and consists of anchor nodes, i.e. the CBD and a number of Urban Hubs, as well as Activity Corridors between these anchor nodes. |
| PRIORITISED PEDESTRIAN NETWORK | A portion of the Public Space Network that is prioritised in order to focus movement onto key routes and at strategic points. |

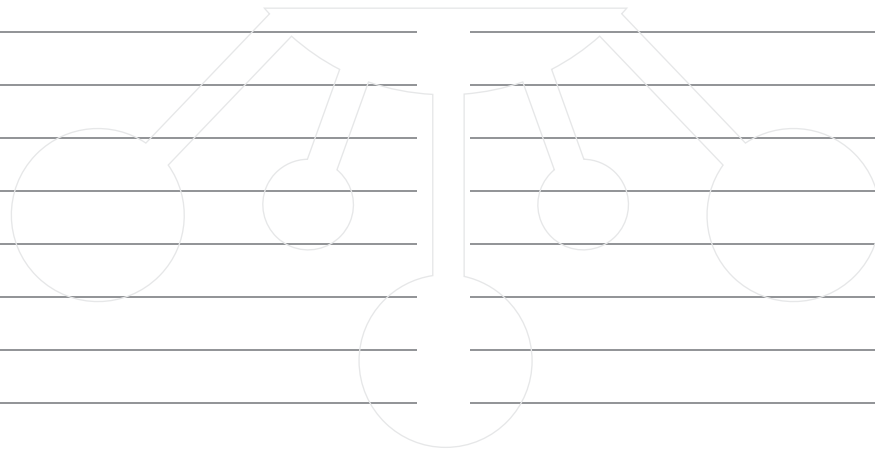
| | |
|---|--|
| PRIORITISED PUBLIC SPACE NETWORK | The prioritised links and spaces of the Public Space Network in terms of their centrality and connective capacity between the "Interchange Zone" and the remainder of the Hub Precinct. |
| PUBLIC REALM | Space outside of the privatised and securitised precincts and buildings which is perceived to be part of a broader shared domain. |
| PUBLIC SPACE | Public space includes all land that does not belong to private individuals or institutions and which is accessible to the broader public for circulation, socialising, trading, events etc. |
| PUBLIC SPACE NETWORK | A connected group of spaces, places and routes that facilitate movement across urban areas but which can also serve a recreational, utility, environmental, social and economic role. |
| SECONDARY NETWORK | The network at the scale of the township or a cluster of townships. It includes the Urban Hub and a number of Secondary Nodes as well as Secondary Transport Linkages between these nodes. |
| SUB-PRECINCT | The sub-precinct in the context of this toolkit refers to smaller portions of the Precincts defined above which can be regarded as focus areas for design and / or implementation purposes. These areas can be planned for independently after framework planning for the entire Hub has been undertaken. |
| URBAN HUB | The urban node that is the focus of the present exercise which seek to develop town centres within the township areas. It is the intention that these will function as Primary nodes. |
| URBAN NETWORK | The Urban Network consists of a primary and secondary network which interconnect at strategic nodes known as Urban Hubs, which are located within townships. |



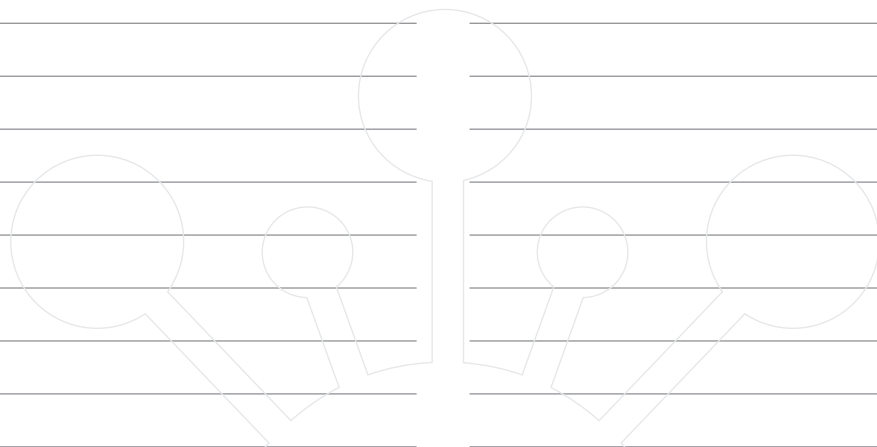
NOTES



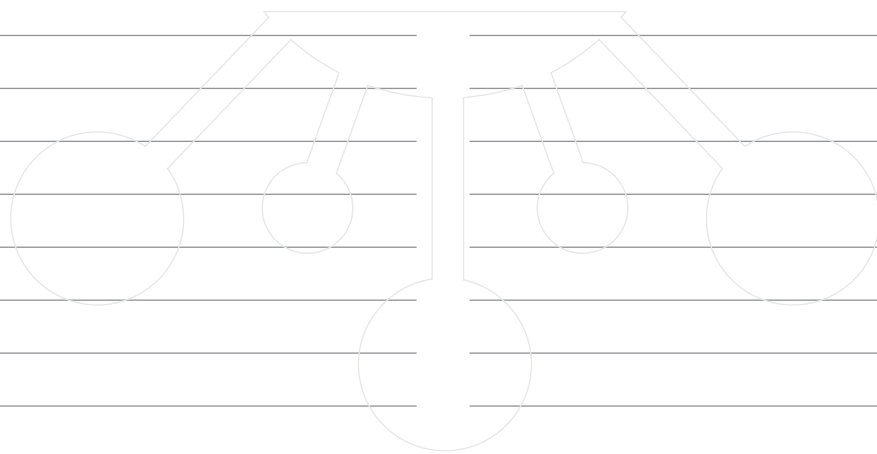
CREATING URBAN NETWORKS.
RESHAPING SOUTH AFRICA'S CITIES.



NOTES



CREATING URBAN NETWORKS.
RESHAPING SOUTH AFRICA'S CITIES.





Neighbourhood Development Programme

URBAN HUB DESIGN TOOLKIT

THE MUNICIPAL GUIDE: *Getting your hub started*



national treasury

Department:
National Treasury
REPUBLIC OF SOUTH AFRICA

